

D

HYDRAULIC PUMPS & POWER UNITS



SPES45054WPL



SPES3502AR

THE **SPE 35 & 45 SERIES** ARE COMPACT PORTABLE ELECTRIC POWER UNITS.

These powerful units are lightweight, cost effective and have a number of valve and pump functionality options to ensure that there is a suitable pump for every application. Having low amperage draw motors they are ideal for field use or indoors.

Model	Usable Oil (L)	Pressure Stage	Flow (Lpm)	Piston Rod speed (mm) per second	Force (ton)											
					10	15	20	25	30	50	75	100	150	200		
Two Speed																
35 Series - Two Speed	1.6	1st	2.00		23.0	16.0	12.0	10.0	8.0	4.0	3.0	3.0	-	-		
		2nd	0.20		2.0	1.6	1.2	1.0	0.8	0.4	0.3	0.3	-	-		
45 Series - Two Speed	4*	1st	2.50		29.0	21.0	15.0	13.0	10.0	5.0	4.0	3.0	2.1	1.6		
		2nd	0.35		4.0	3.0	2.0	2.0	1.4	0.8	0.6	0.4	0.3	0.2		

* A 2 L tank is also available – to order the smaller tank size; remove "L" from the end of the model number, eg. "SPES45054WP"

STEEL OIL RESERVOIR

with internal bladder allows pump to be used at any angle

REMOTE PENDANT CONTROL

2.5 M is standard supply on all 35-Series

ELECTRIC COMMUTATOR MOTOR

0.35 kW (0.47 HP)
230 V 50/60 Hz 2.5 A or
115 V 50/60 Hz 6 A (option)

DIRECTIONAL CONTROL VALVES

available in manual or solenoid versions to suit single and double acting cylinders

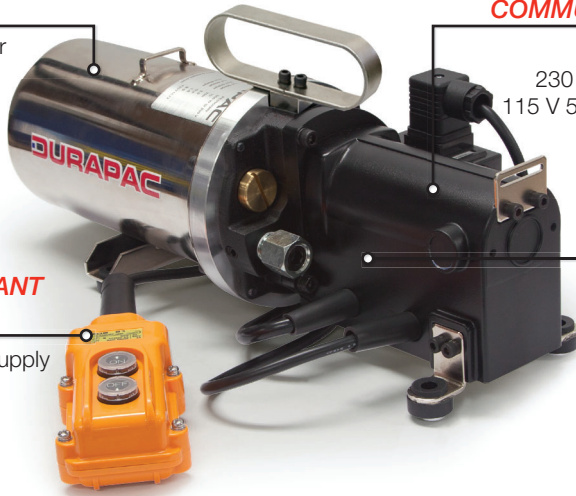

MOTOR SIZE RANGE

0.35 - 0.45 kW

FLOW RANGE

0.2 - 0.35 Lpm @ 700 bar

MAXIMUM OPERATING PRESSURE

700 bar

PRESSURE GAUGE

63 mm diam. 0-1,000 bar as standard on all 45-Series

ONE PIECE ALLOY RESERVOIR

for lightweight durability

RESERVOIR SIGHT GAUGE

to monitor oil level

ELECTRIC COMMUTATOR MOTOR

0.45 kW (0.6 HP)
230 V 50/60 Hz 4.5 A
or 115 V 50/60 Hz 11A (option)

DIRECTIONAL CONTROL VALVES

available in manual or solenoid versions to suit single and double acting cylinders

REMOTE PENDANT CONTROL

2.5 M is standard supply on all 45-Series

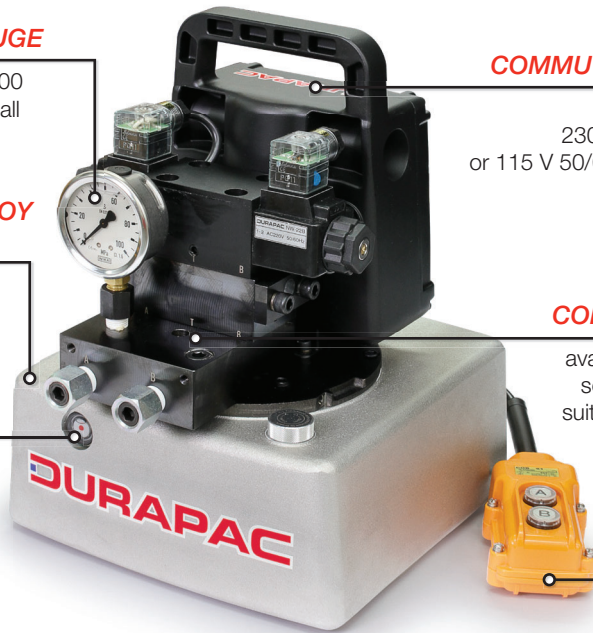

PERFORMANCE TABLE

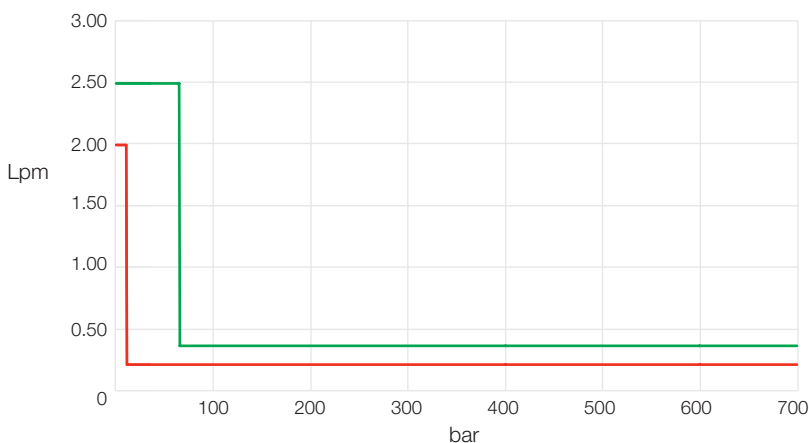

Two Speed
 — SPE 35-Series
 — SPE 45-Series

ELECTRIC HYDRAULIC POWER UNITS

SPES3502NC

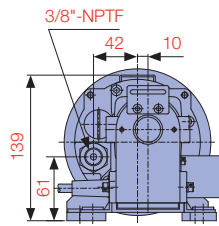

THE **SPE35-SERIES** POWER UNITS ARE CONFIGURED WITH A NUMBER OF VALVE AND PUMP FUNCTIONALITY OPTIONS TO ENSURE THAT THERE IS A SUITABLE POWER UNIT FOR EVERY APPLICATION.

Cost effective, portable and powerful, these units are lightweight and have shoulder strap and handle for transport ease. Extremely simple to use. A pressure switch is an available option on the 35 Series.

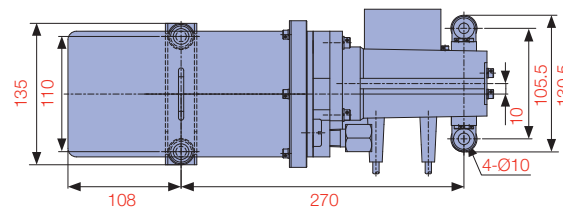
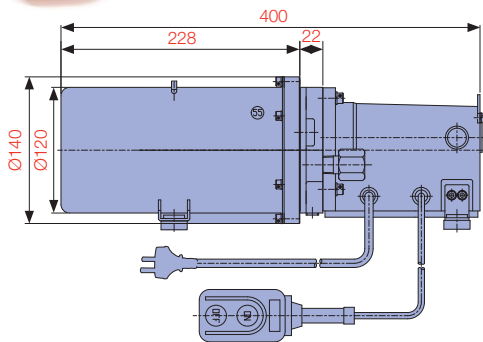

SPES3502NO

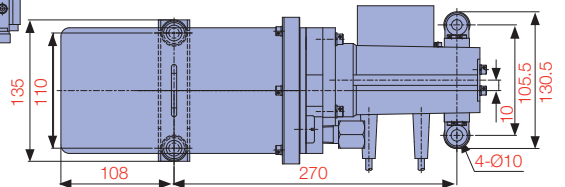
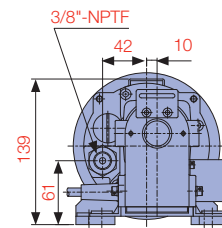
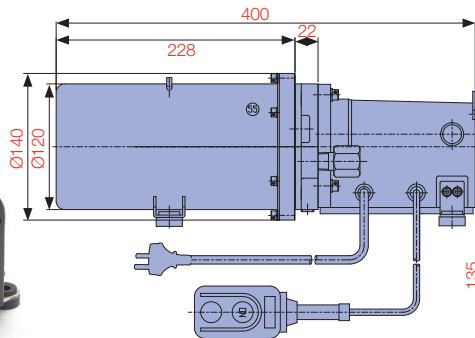

Model	Motor (kW)	Voltage† (1 Ph.)	Hz	Amps	Pressure Rating (bar)	Flow Rate (Lpm)		Control Switch	Usable Oil Capacity (L)
						10 bar	700 bar		
SPE35 Series	0.35	230	50/60	2.5	700	2.0	0.2	Remote ON/OFF	1.6
		115	50/60	6.0					

Model Number	Valve Type	Used with Cylinder	Cylinder/Pump Function	Weight (kg)
SPES3502NC	Solenoid Pressure Hold Type	S/A	"Advance" when ON switch is pressed and the motor starts, Release ON switch to "Hold" and stop the motor, "Retract" when OFF switch is pressed. Cylinder cannot be stopped on "Retract"	8.7
SPES3502NO	Solenoid Auto Retract Type	S/A	"Advance" when ON switch is pressed and the motor starts, Auto "Retract" when ON switch is released. The optional pressure switch allows the cylinder to be stopped at set pressure and return automatically	8.7
SPES3502AR	Internal "Pop Off" Valve, Auto Retract Type	S/A	"Advance" when ON switch is pressed and the motor starts. Pop Off relief valve will indicate full pressure. Auto "Retract" when ON switch is released	8.4
SPES3502IN	Solenoid Pressure Hold Type	S/A	"Advance" when ON switch is pressed and the motor starts, Release ON switch to "Hold" and stop the motor, "Retract" when OFF switch is pressed. Cylinder can be stopped on "Retract"	9.0
SPEM35024	4w/3p Manual	D/A	When ON switch is pressed, motor will start. When ON switch is released, motor will stop. Advance, Hold, Retract via manual valve	9.7

† Standard motor supplied is 230V, should 115V be required; add "-115V" to the end of the model number

SPES3502AR

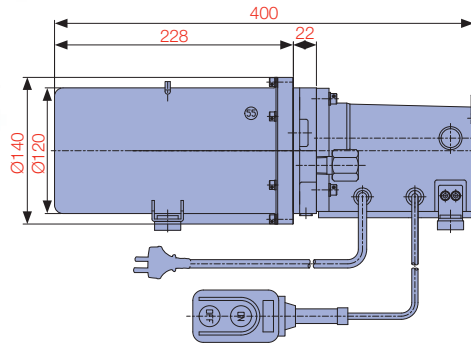
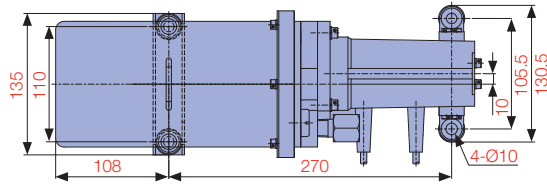
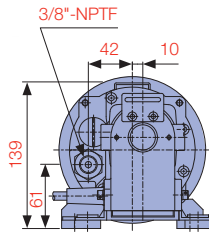

OIL CAPACITY

1,600 cc

FLOW

2.0 Lpm @ 10 bar

0.2 Lpm @ 700 bar

MAXIMUM OPERATING PRESSURE

700 bar

SPES3502IN

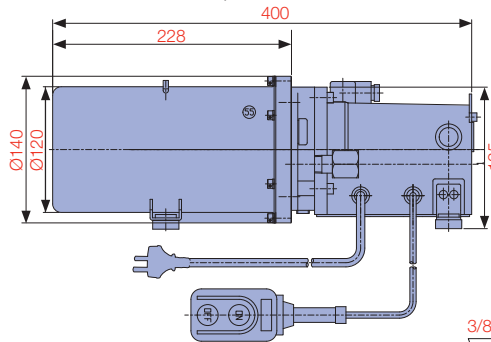
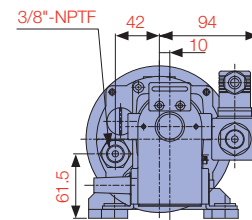
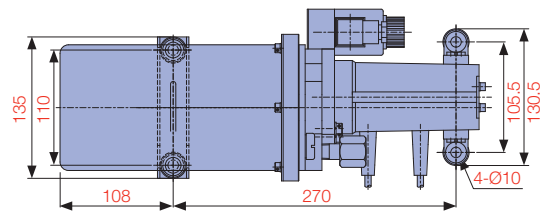

SPEM35024

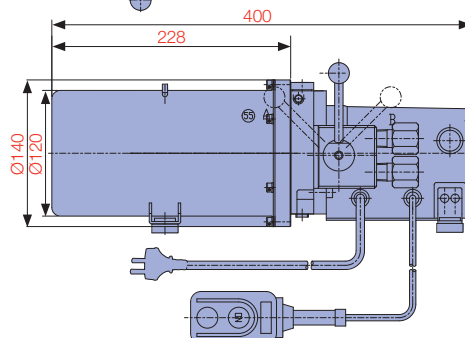
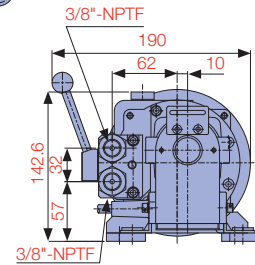
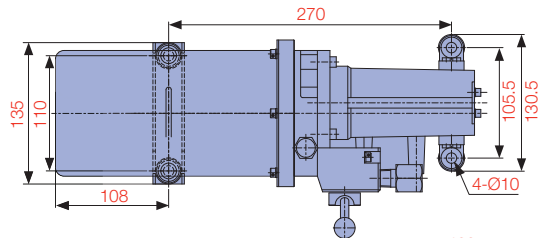

D

HYDRAULIC PUMPS & POWER UNITS



SPE4505NCL



SPEM45054L

THE **SPE45-SERIES** POWER UNITS ARE CONFIGURED WITH A NUMBER OF VALVE AND PUMP FUNCTIONALITY OPTIONS TO ENSURE THAT THERE IS A SUITABLE PUMP FOR EVERY APPLICATION.

Cost effective, portable and powerful these units are lightweight and have a carry handle integrated into the shroud. Extremely simple to use. Pressure switch, adjustable pressure relief and pilot check valves are available options on the 45 Series.

Model	Motor (kW)	Voltage† (1 Ph.)	Hz	Amps	Pressure Rating (bar)	Flow Rate (Lpm)		Fitted with	Usable Oil Capacity (L)	Optional Small Tank Usable Oil Capacity* (L)
						70 bar	700 bar			
SPE45 Series	0.45	230	50/60	4.5	700	2.5	0.35	Pressure Gauge	4	2
		115	50/60	11.0						

Model Number	Valve Type	Used with Cylinder	Pump Function	Remote Pendant Function 2.4 M	Weight (kg)
SPEM4505ML	Basic	S/A	P.T. manifold, without valve	MOTOR ON/OFF	17.8
SPEM45053L	3w/2p Manual	S/A	Advance, Hold, Retract via manual valve	MOTOR ON/OFF	19.6
SPES4505NCL	3w/2p Solenoid	S/A	"Advance" when ON switch is pressed and the motor starts, Release ON switch to "Hold" and stop the motor, "Retract" when OFF switch is pressed	Adv/Hold/Retract	21.0
SPES4505NOL	2w/2p Solenoid	S/A	"Advance" when ON switch is pressed and the motor starts, Auto "Retract" when ON switch is released	MOTOR ON/OFF	22.0
SPEM45054L	4w/3p Manual	D/A	Advance, Hold, Retract via manual valve	MOTOR ON/OFF	19.6
SPES45054SPL	4w/3p Solenoid	D/A	Advance/Hold/Retract with stacking type pilot-operated check valve fitted on "A" port line	Adv/Hold/Retract	22.0
SPES45054WPL	4w/3p Solenoid	D/A	Advance/Hold/Retract with stacking type pilot-operated check valve fitted on "A" and "B" port lines. Pressure holding on both "A" and "B" ports	Adv/Hold/Retract	22.0

* To order the smaller tank size; remove "L" from the end of the model number, eg. "SPES45054WP"
 † Standard motor supplied is 230V, should 115V be required; add "-115V" to the end of the model number

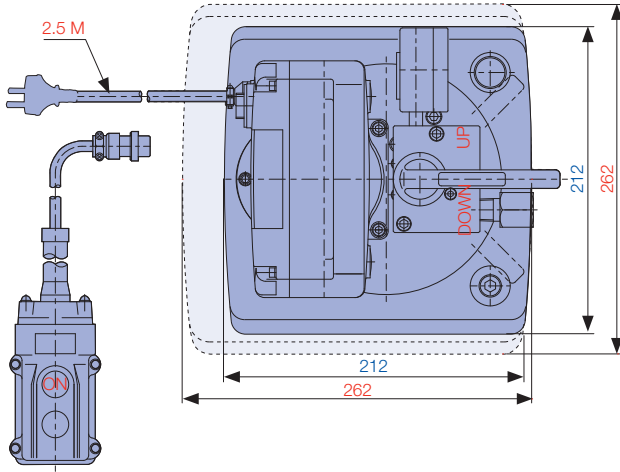

MOTOR SIZE
0.45 kW

FLOW
0.35 Lpm @ 700 bar

MAXIMUM OPERATING PRESSURE
700 bar

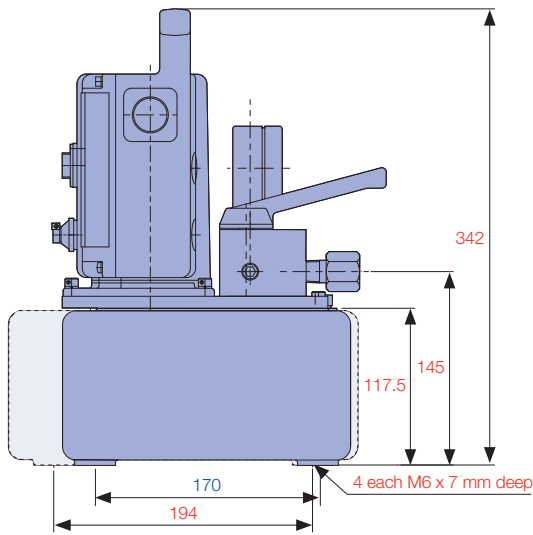
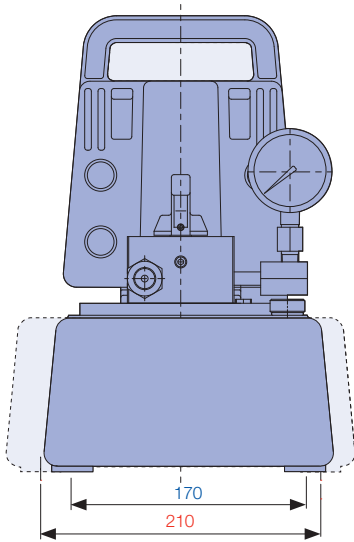

- SPES45054WPL
- SPES4505NCL
- SPEM45054L
- SPES45054SPL
- SPES4505NOL
- SPEM45053L

